

THIS DRAWING IS UNPUBLISHED. RELEASED FOR PUBLICATION ,19 .  
 © COPYRIGHT 19 BY AMP INCORPORATED. ALL RIGHTS RESERVED.

| LOC | DIST | REVISIONS   |                    |         |       |
|-----|------|-------------|--------------------|---------|-------|
| P   | LTR  | DESCRIPTION | DATE               | DWN     | APVD  |
| G   | 14   | C           | REV / 0720-0967-96 | 09SEP96 | ME TM |

|                                |                                |                                |
|--------------------------------|--------------------------------|--------------------------------|
| <b>AMP</b><br>WIRE RANGE       | <b>UL</b> E13288               | <b>SR</b> LR7189<br>Certified  |
| 12-10 AWG<br>SOLID OR STRANDED | 12-10 AWG<br>SOLID OR STRANDED | 12-10 AWG<br>SOLID OR STRANDED |

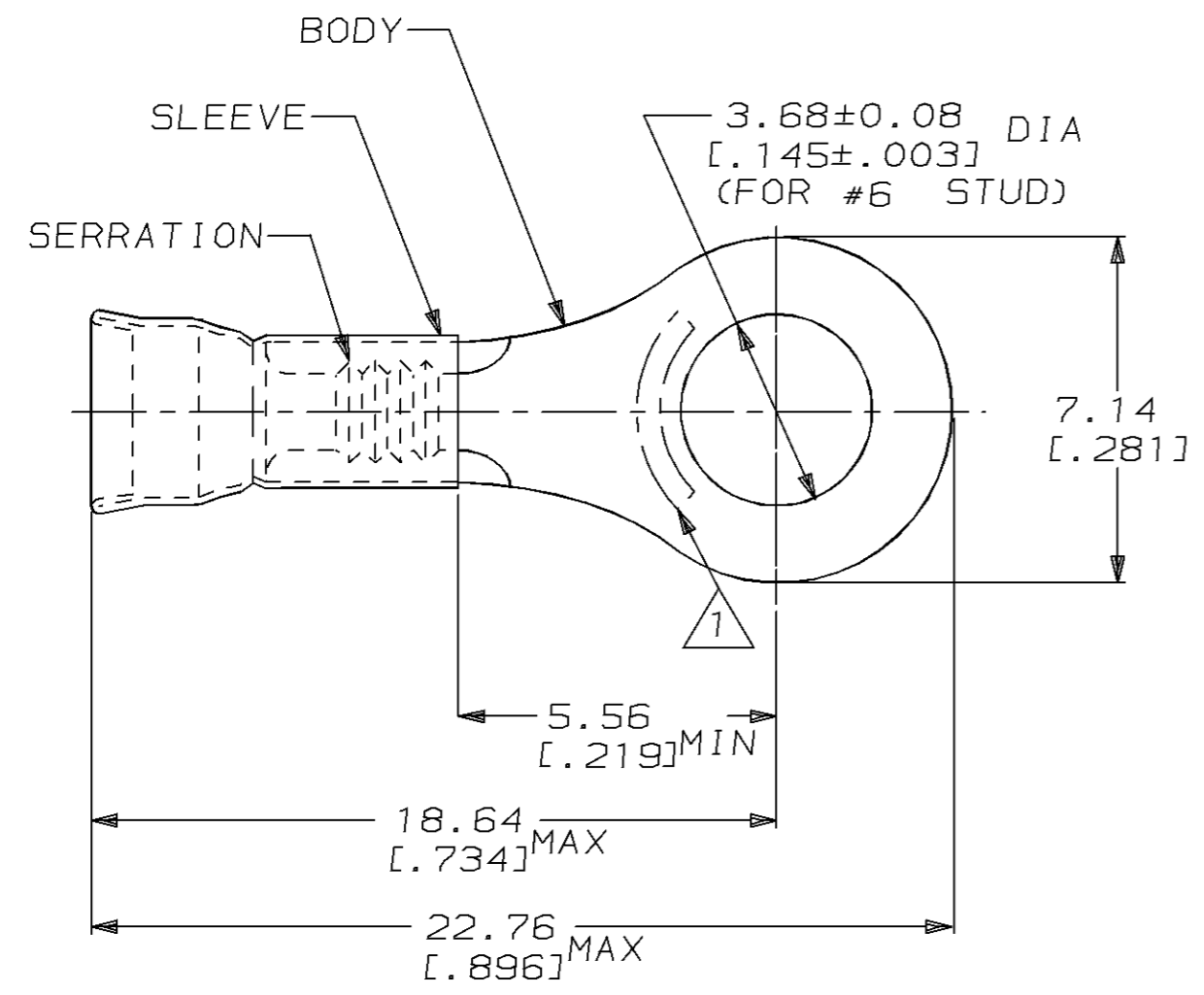

1. STAMP AMP 12-10\* LOCATE APPROX AS SHOWN

- 2. WIRE INSUL DIA, 3.81-5.84 [.150-.230]
- 3. TONGUE MATL THK, 1.02±0.05 [.040±.002]

|      |              |            |
|------|--------------|------------|
| 2000 | ONTAPE, REEL | 2-321501-1 |
| 500  | LOOSE PIECE  | 321501     |
| QTY  | PACKAGE TYPE | PART NO    |

|  |  |   |  |  |   |  |
|--|--|---|--|--|---|--|
| AMP INCORPORATED<br>CUSTOMER SERVICE SYSTEM                                      |  | MAX RECOMMENDED OPERATING TEMPERATURE:<br>170°C [338°F] | THIS DRAWING IS A CONTROLLED DOCUMENT FOR AMP INCORPORATED.<br>IT IS SUBJECT TO CHANGE AND THE CONTROLLING ENGINEERING ORGANIZATION SHOULD BE CONTACTED FOR THE LATEST REVISION. |  | DWN<br>L OLMEDA<br>23JAN95  | <b>AMP</b> AMP Incorporated<br>Harrisburg, PA 17105-3608         |
| FOR ADDITIONAL PRODUCT INFORMATION OR COPIES OF DRAWINGS AND TECHNICAL DOCUMENTS | PRODUCT INFORMATION CENTER<br>1-800-522-6752 |   | VOLTAGE RATING:<br>-   | DIMENSIONS:<br>mm [in]                         | TOLERANCES UNLESS OTHERWISE SPECIFIED:                              |  |
| FOR APPLICATION TOOLING INFORMATION  | TOOLING ASSISTANCE CENTER<br>1-800-722-1111  | CIRCULAR MIL AREA:<br>2.62mm²-6.64mm² [5180-13100]      |  | 0 PLC ±-                                       | APVD<br>S BORTNER<br>23JAN95  | NAME<br>TERMINAL, RING,<br>DIAMOND GRIP,<br>WIRE SIZE, 12-10 AWG |
| FOR ORDER ENTRY  | 1-800-526-5142                               | -   |  | MATERIAL<br>BODY, CU, SLV, CU PER<br>ASTM B152 | 1 PLC ±-<br>2 PLC ±0.20 [.008]<br>3 PLC ±-<br>4 PLC ±-<br>ANGLES ±- | PRODUCT SPEC<br>UL486A   |
|  |  |   | FINISH<br>TIN PLATE<br>PER MIL-T-10727   | WEIGHT<br>-                                    | APPLICATION SPEC<br>-   | CAGE CODE<br>00779   |
|  |  |   |  | CUSTOMER DRAWING                               | DRAWING NO<br>C-321501  | SCALE<br>6:1   |
|  |  |   |  |  |   | SHEET<br>1 OF 1  |
|  |  |   |  |  |   | REV<br>C   |